

Reliable & Low Maintenance



**QUANTUM**  
Q500 Parallel Shaft  
Fan Drive



[www.amarillogear.com](http://www.amarillogear.com)  
[info@amarillogear.com](mailto:info@amarillogear.com)  
(806) 622-1273



# Quantum Series Parallel Shaft Fan Drive for Dry Cooling Systems

The Quantum Series Parallel Shaft Fan Drive for dry cooling systems reflect a long history of quality workmanship and reliability. Amarillo Gear Company has been designing and manufacturing application specific gear drives since 1934, and the commitment to excellence continues today. One example of this commitment is the availability of complete noise and vibration testing, with all data taken under full power loading, up to 250 hp (186 kW).

All fan drives are spin tested prior to shipment and a complete conformity check is made. This ensures that Amarillo supplies the product exactly as required and it will provide reliable service demanded by the owner.

Having a parallel shaft fan drive specifically designed for dry cooling systems means the process for selecting the correct fan drive is simple. It's as easy as following the steps shown below. For unusual applications, or extreme operating conditions, contact Amarillo Gear Company for help making the correct selection.

## **Quantum Series Parallel Shaft Fan Drive selection**

1. Calculate the required ratio by dividing the motor speed (input) by the desired fan speed (output).
2. Select the fan drive from Table 1 that has a motor power rating, under the required ratio column, that is equal or greater than the motor power at the motor speed. All ratings include an AGMA 2.0 service factor on motor nameplate power which is generally recommended by leading industry designers of Air Cooled Condenser systems for long life and required reliability.

**Table 1 – Service Power Ratings (AGMA Service Factor = 2.0 on motor nameplate power)**

<b>Horse Power Rating</b>		<b>Exact Ratio</b>					
Model	Input RPM	18.22	19.27	19.78	20.82	22.02	22.60
Q-500	1750	254	263	250	254	259	250
	1500	218	225	214	218	222	214
	1200	174	180	172	174	178	172

Vertical Down Thrust Capacity: 10,500 lbs. (47kN)

<b>Kilowatt Power Rating</b>		<b>Exact Ratio</b>					
Model	Input RPM	18.22	19.27	19.78	20.82	22.02	22.60
Q-500	1750	189	196	186	189	193	186
	1500	162	168	159	162	165	159
	1200	130	134	128	130	132	128

The Q-500 Parallel Shaft Fan Drive is designed to ensure that the thermal rating meets or exceeds the service (motor power) rating in Table 1 when the ambient temperature is 120°F or less. No thermal calculations are required. For rare applications where the ambient temperature is above 120°F, contact Amarillo Gear Company for thermal ratings for your specific project conditions.

The Quantum Series Parallel Shaft Fan Drive is designed and manufactured specifically for the demanding environment of dry cooling systems. As with any precision machine component, proper selection, installation, maintenance and operating procedures are imperative for long life and trouble-free service. Our engineers will be pleased to assist with unusual conditions that require special procedures, options, or modifications.

## **What To Consider?**

### **Ratio**

All ratios are reducing and defined as the ratio of the input speed to output speed. Exact ratios are noted in Table 1. Special ratios may be available for specific applications. Please contact Amarillo Gear Company for more information.

### **Ratings**

Amarillo Gear Company recommends a minimum AGMA Service Factor of 2.0 on motor name plate power for gear drives in ACC fan service. The service ratings (motor power rating) noted in Table 1 includes an AGMA service factor of 2.0 on motor name plate power. Ratings are listed for 60 and 50 Hertz electric motor speeds. Ratings at intermediate speeds may be interpolated from the table. Contact the factory for recommendations when the electric motor speed is outside the table range. Design features and ratings are in accordance with, or exceed, the minimum requirements of AGMA (American Gear Manufacturers Association) and CTI (Cooling Technology Institute) standards.

### **Direction of Rotation**

Normal rotation is both shafts clockwise, when viewed from the top. Occasional use with both shafts rotating counterclockwise is permissible (as long as a non-reverse backstop is not used). Special bearing arrangements are used when the primary direction of rotation is counterclockwise, incurring additional cost, and the fan drives should be ordered accordingly.

### **Quantum Series Standard Features**

The Quantum Series Parallel Shaft Fan Drive is patent pending and revolutionary in the design of gears for use in ACC's, and provides solutions to common complaints expressed by owners of this type of equipment. The Quantum design is for the owner who seeks to improve the reliability of his rotating equipment and significantly reduce costly repairs and down time.

### **Heat Dissipation**

The Q-500 fan drive is a power dense compact design incorporating the use of cooling fins for efficient heat dissipation while also providing supreme gear box rigidity.

## **Housing and Castings**

Castings are rigidly designed, using finite element analysis, and constructed to absorb internal and external loads with minimum deflection. The gear case is a split case design, with both case and cover doweled together to assure permanent alignment of bearings and gears under load. The interior features a sloped floor that permits complete drainage of oil when a change is required. All casting materials are ASTM A48 Class 30 gray iron for effective damping of noise and vibration. All mating castings are sealed using “form-in-place” gasket material, eliminating leaks caused by other sealing materials. The Quantum Series has mounting provisions for easy installation of accelerometers for vibration monitoring of each shaft. Mounting feet are predrilled with pilot holes to assist in installation of dowel pins.

## **Helical Gears**

Amarillo Gear Company manufactures in house (U.S.A.) the helical gearing for the Quantum Series Parallel Shaft Fan Drive. This allows Amarillo 100% quality control. Helical gears are designed and manufactured from nickel alloy steel. The gears are case hardened to ensure optimum tooth strength and precision ground to a minimum AGMA class Q-11 quality level to provide low-noise, low vibration operation.

## **Quiet Operation**

Quiet operation of the Quantum Series Parallel Shaft Fan Drive is achieved through careful design and controlled manufacturing methods of all components. Amarillo Gear engineers understand the many parameters that affect gear noise and have applied the latest research to the design of the Quantum Series Parallel Shaft Fan Drive. Rigid shafts and rigid, permanently aligned housings, guarantee precise alignment of gears under load. Test results collected in our on-site test facility prove that our sound levels are among the lowest available in the industry.

*Please see table on A-Weighted Sound Power for specific data.*

## **Efficient Operation and Design**

The Q-500 parallel shaft fan drive is proven to be 98% efficient under full load. The Quantum series also features efficient design by significantly reducing the number of parts typically found in a parallel shaft gear box thereby contributing to the Quantum’s reliability.

## **Bearings**

All bearings are roller type, sourced from major Tier 1 manufacturers. Bearing spans are maximized for rigidity and increased bearing life. The fan shaft thrust bearing is designed and sized to carry all loads imposed by the fan while maintaining 100,000 L<sub>10</sub> life. All bearings are sized to meet or exceed the minimum life requirements of AGMA and CTI. All bearings are sized to the metric standard for easy, worldwide sourcing if replacement is necessary.

## **Seals on Input and Output Shafts**

The Quantum Series is unique in the industry in that a non-contact bearing isolator seal is used on the input shaft. Typical designs use lip seals which have a finite life dictated by time and use. These older designs require costly shut downs for repair and maintenance. Since the bearing isolator used on the Quantum input shaft is non-contact, it should last the life of the fan drive and never require maintenance.

The Quantum Series is also unique in that it features a true dry well patent pending design for the output shaft. No seal is required or installed on this shaft that can wear and require costly maintenance and shutdowns. Amarillo Gear is a recognized expert in the design of dry well constructed gear boxes having used a similar design in a gear box produced for over 70 years.

## Shafting

The Quantum series features input and output shafts properly designed and sized for rugged use in an ACC. Shafts are manufactured from alloy steel and all surfaces are precision machined to insure proper installation of the gears, bearings, input coupling and fan hub. A retaining plate is also provided on the output shaft to add additional security for interference fit fan hubs. The output shaft is available to a length specified by the customer.

## Lubrication

An internal positive displacement oil pump provides bidirectional lubrication. All plumbing is internal to the gear case (except where an optional oil filter is specified) eliminating the risk of external oil leaks and handling damage. A dip stick and permanently mounted oil level sight gauge is provided on all units to provide direct visual determination of oil level. Sump magnets are also standard on the Quantum series. Amarillo also offers the popular GSU (Gear Service Unit) to further minimize maintenance of lubrication of the fan drive and to extend lubricants serviceable life. Contact Amarillo Gear for more information on the GSU.

Another feature of the Quantum series is that ***no greasing of oil seals and bearings are required.*** All lubrication is provided by the generous oil sump. This eliminates costly shut downs and leaks related to overfilling or using the wrong grease.

## Breathers

Each Quantum series fan drive is shipped with a hygroscopic breather to absorb moisture before it enters the fan drive. The breather is shipped loose with the fan drive and should be installed at the time of operation to ensure maximum life of the breather.

## Motor Stand

Amarillo Gear has designed the motor stand for the Quantum series to rigidly and safely support common motors in use today. For your specific motor application, please contact Amarillo Gear Company.

## Retrofit Replacement for Other Models

The Quantum series, specifically the Q-500, is designed as a drop in replacement for parallel shaft gear drives produced by other manufacturers. Please contact Amarillo Gear to find out how the Quantum series can bring reliability to your dry cooling system.

## Extended Limited Warranty

Amarillo Gear is pleased to offer as standard, a 36 month limited warranty on the Quantum Q-500 parallel shaft fan drive. For details, please contact Amarillo Gear Company.

## Popular Options

Amarillo Gear Company is pleased to offer many popular options requested by its customers to ensure the fan drive performs as required. Some of the options are listed below:

- Oil Filter (10 micron, spin on type)
- Non-reverse backstop (internal)
- Oil pressure switch or transmitters
- Low oil level switch or transmitters
- Special marine paint finishes and colors
- Oil temperature switch or transmitters
- Extended lower bearing housing for increasing fan stability caused by dynamic loads
- Motor to fan drive coupling
- Oil heaters and thermostat
- Oil sampling port

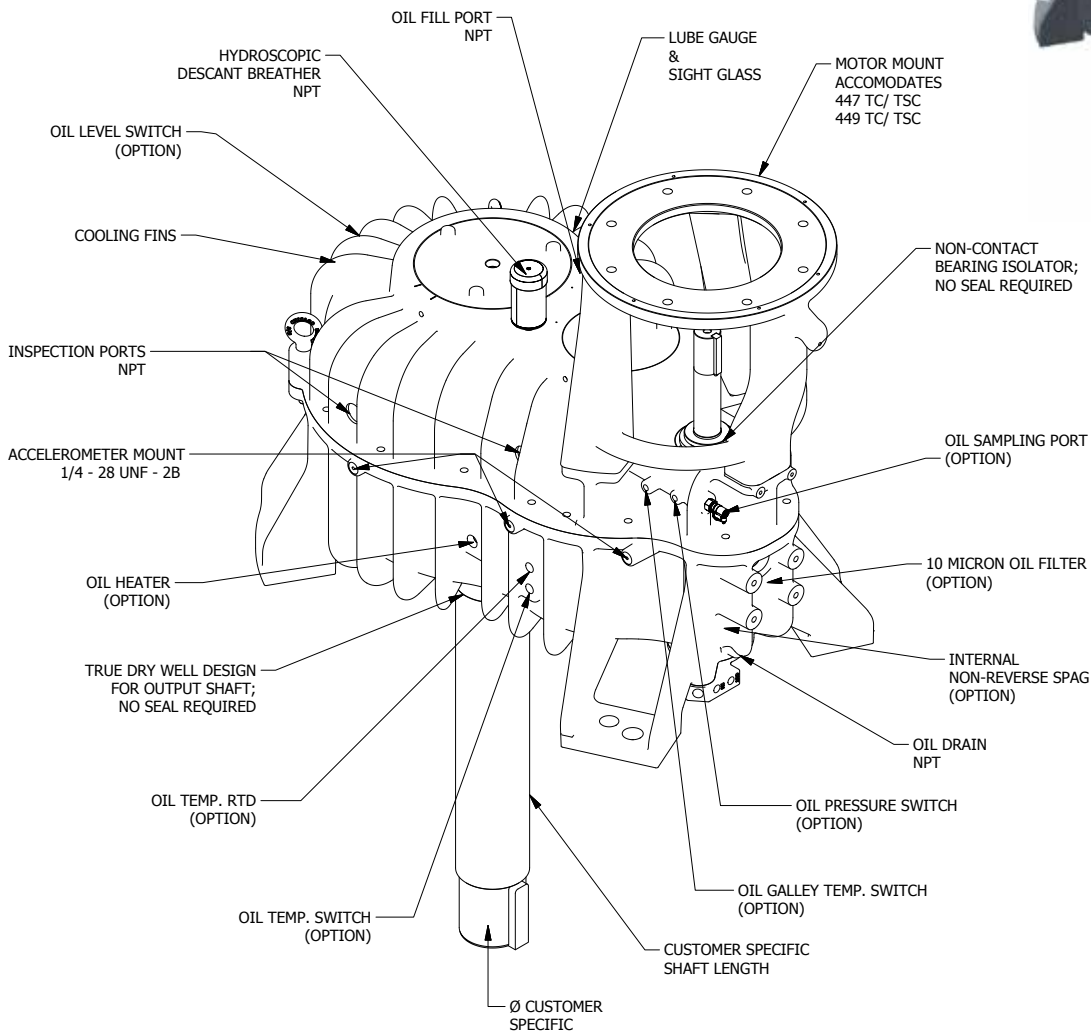

# QUANTUM Q-500 DIMENSIONS

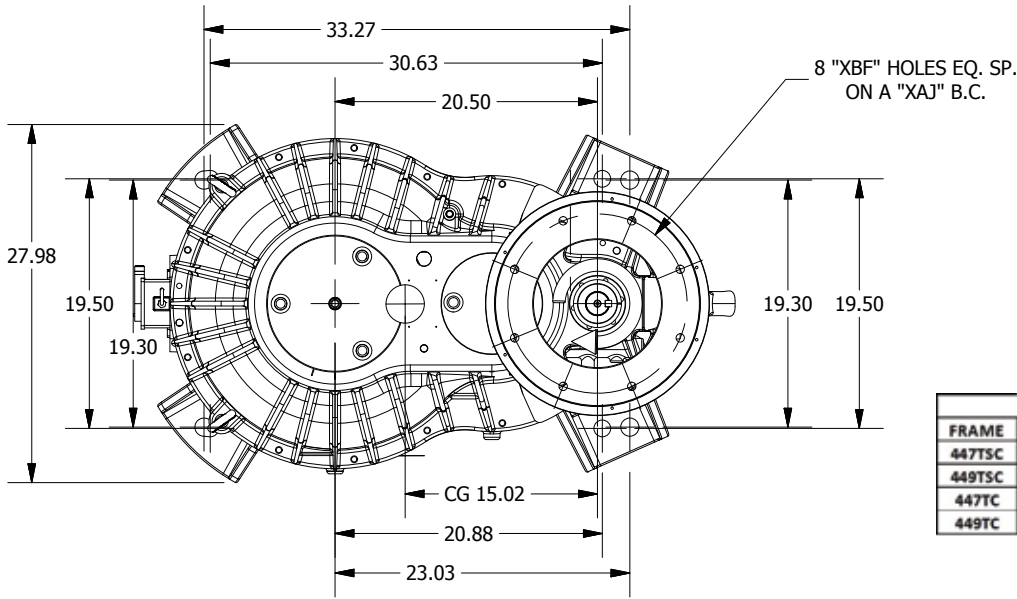

MOTOR MOUNT DIMENSIONS (INCH)					
FRAME	XAJ	XAK	XBD	XBF	XN
447TSC	14	16	18	11/16	A+4.75
449TSC	14	16	18	11/16	A+4.75
447TC	14	16	18	11/16	A+8.50
449TC	14	16	18	11/16	A+8.50

A-WEIGHTED SOUND POWER	
OPERATING CONDITIONS	dBA
1160 rpm; 165 hp	82
1450 rpm; 207 hp	84
1750 rpm; 200 hp	89
1750 rpm; 250 hp	89

*WEIGHT (lb)	
GEARBOX AS SHIPPED (DRY)	1920
GEARBOX W/ OIL	2000
* WEIGHT VARIES WITH OUTPUT SHAFT LENGTH	

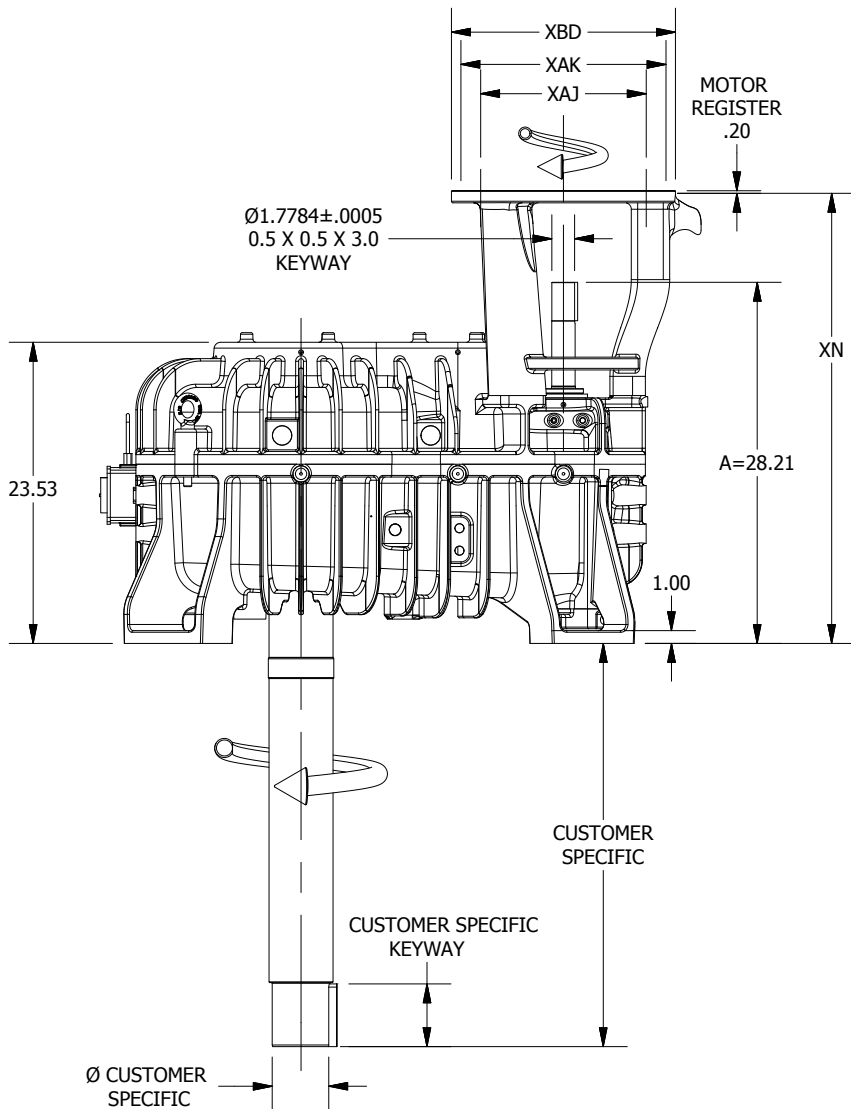

Reliable & Low Maintenance



## Who to Contact?

For general inquiries, please contact us:

Phone: 806 622 1273

Fax: 806 622 3258

Email: [info@amarillogear.com](mailto:info@amarillogear.com)

**Amarillo Gear Company LLC**

2401 Sundown Lane

Amarillo, Texas 79118

[www.amarillogear.com](http://www.amarillogear.com)



[www.amarillogear.com](http://www.amarillogear.com)

[info@amarillogear.com](mailto:info@amarillogear.com)

(806) 622-1273



A Marmon Water/Berkshire Hathaway Company